

NOMINAL ^a					SPECIFIED				
Steel name	Steel number	Diameter ^b	Cross-sectional area	Tensile strength	Mass per metre ^c	Permitted deviation on mass per metre	Characteristic value of maximum force	Maximum value of maximum force	Characteristic value of 0.1% proof force ^d
		d	S _n	R _m	M		F _m	F _{m,max}	F _{p0,1}
		mm	mm ²	MPa	g/m	%	kN	kN	kN
Y1570C	1.1350	9.4	69.4	1570	542.0	± 2	109	125	94.8
		9.5	70.9		553.7		111	128	96.6
		9.7	73.9		577.2		116	133	101
		10.0	78.5		613.1		123	141	107
		10.5	86.6		676.3		136	156	118
		11.0	95.0		742.0		149	171	130
Y1670C	1.1351	6.9	37.4	1670	292.1	± 2	62.5	71.9	55.0
		7.0	38.5		300.7		64.3	73.9	56.6
		7.5	44.2		345.2		73.8	84.9	64.9
		8.0	50.3		392.8		84.0	96.6	73.9
Y1770C	1.1352	3.0	7.10	1770	55.5	± 2	12.6	14.5	11.1
		4.0	12.6		98.4		22.3	25.6	19.6
		4.5	15.9		124.2		28.1	32.3	24.7
		5.0	19.6		153.1		34.7	39.9	30.5
		5.5	23.8		185.9		42.1	48.4	37.0
		6.0	28.3		221.0		50.1	57.6	44.1
Y1860C	1.1353	3.0	7.10	1860	55.5	± 2	13.2	15.2	11.7
		4.0	12.6		98.4		23.4	26.9	20.8
		5.0	19.6		153.1		36.5	42.0	32.5

^a The modulus of elasticity may be taken by convention as equal to 205 GPa (kN/mm²)

^b Plain wires shall have an ovality of 1% of the nominal diameter

^c The nominal mass per metre is calculated from the nominal cross-sectional area and a density of 7.81 kg/dm³

^d The specified characteristic value of the 0.1% proof force is calculated:

- For grade Y1570C with diameters over 8 mm as 87% of the specified characteristic value of the maximum force;
- For the grade Y1860C for all diameters as 89% of the specified characteristic value of the maximum force;
- For all other grades and diameters, as 88% of the specified characteristic value of the maximum force.

prEN 10138:2006 Prestressing Steels Part
1: General requirements + Part 2 Wire

SPECIFIED INDENTATION DIMENSIONS FOR INDENT TYPE T1

Nominal wire diameter (mm)	Range of nominal depths of indentation a		Depth tolerance on chosen nominal depth	Length l	Spacing c
	From	To			
≤ 5	0.06	0.13	± 0.03	3.5 ± 0.5	5.5 ± 0.5
>5 to 8	0.09	0.16	± 0.04	5.0 ± 0.5	8.0 ± 0.5
>8 to 11	0.10	0.20	± 0.05	5.0 ± 0.5	8.0 ± 0.5

SPECIFIED INDENTATION DIMENSIONS FOR INDENT TYPE T2

Nominal wire diameter (mm)	Range of nominal depths of indentation		Depth tolerance on chosen nominal depth	Length	Spacing
	From	To			
>8 to 11 alternative	0.10	0.20	± 0.05	3.5 ± 0.5	5.5 ± 0.5

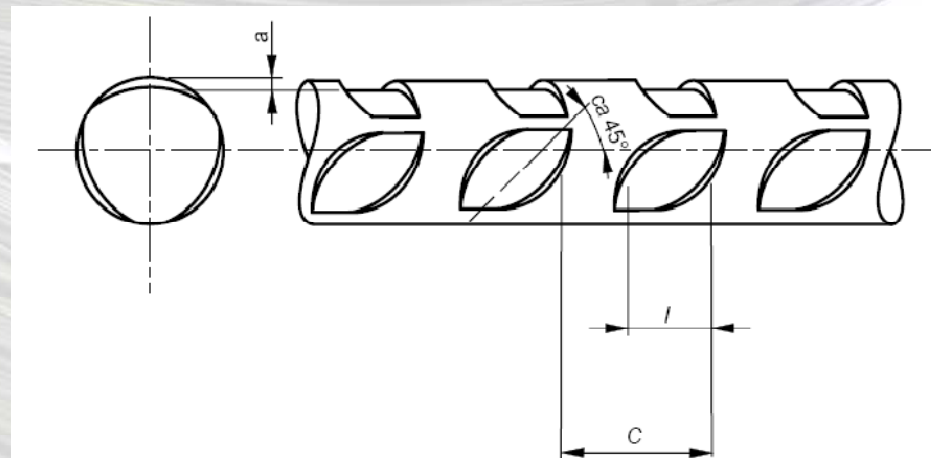

Indentation type T1 and T2

SPECIFIED INDENTATION DIMENSIONS FOR INDENT TYPE T3

Nominal wire diameter (mm)	Range of nominal depths of indentation a		Depth tolerance on chosen nominal depth	Length l	Spacing c
	From	To			
5	0.06	0.16	± 0.04	5.0 ± 1.0	8 ± 18
7	0.06	0.16	± 0.04	5.4 ± 1.0	10 ± 20

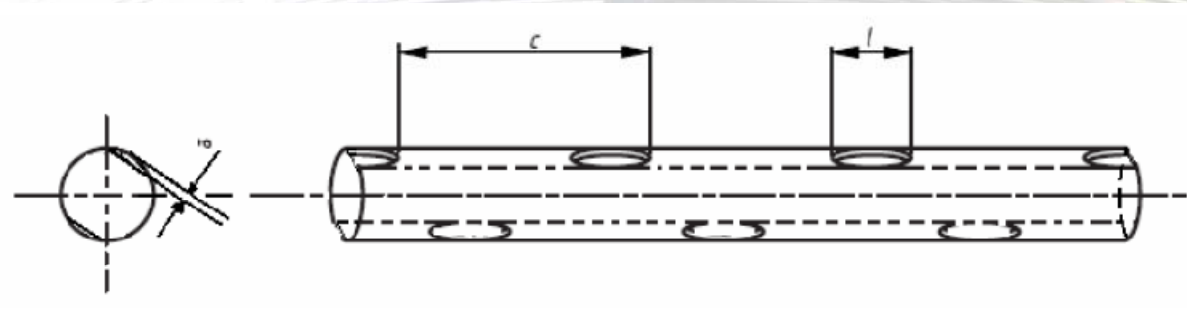

Indent type T3